

SSD-C Series Expansion Joint
Sizes 400 through 1200
(Slab-to-Wall)



50 MM WAY
 PENDERGRASS, GA. 30567
 706-824-7500 PHONE

www.mm.systems

For Spec-Data, Install Guides, and other data visit www.mm.systems

RIGHTS OF DESIGN

All rights of design, detail, engineering and/or invention contained herein are the property of MM Systems and hereby reserved and are not to be reproduced or provided to any other party. MM Systems reserves the right to amend or withdraw any information contained herein without notice and will not be liable for any inaccuracy or ambiguity of said information.

Split-Slab Dual Seismic Foam Seal System





SSD-C Series (400-1200)

Drawn by: LRM	Scale: NTS	Drawing Number: 220324-02
SHT. 1 OF 3	Issue Date: 07/10/2025	

SSD-C SERIES EXPANSION JOINT MOVEMENT CHART

Model Number	Joint Opening (JO ^N)		Sight Line (SL ^N)		Thermal Movement (JO ^T)				Seismic Movement (JO ^S)				Total (JO ^A) Movement		Slide Plate Thickness (ST)	
	Nominal		Nominal		Minimum		Maximum		Minimum		Maximum					
SSD-C-400	4.00	102	5.75	146	3.00	76	5.00	127	3.00	76	5.00	127	2.00	51	0.25	6
SSD-C-500	5.00	127	7.50	191	4.00	102	6.00	152	3.75	95	6.25	159	2.50	64	0.375	10
SSD-C-600	6.00	152	8.00	203	5.00	127	7.00	178	4.50	114	7.50	191	3.00	76	0.375	10
SSD-C-700	7.00	178	10.25	260	6.00	152	8.00	203	5.25	133	8.75	222	3.50	89	0.375	10
SSD-C-800	8.00	203	10.75	273	7.00	178	9.00	229	6.00	152	10.00	254	4.00	102	0.375	10
SSD-C-900	9.00	229	12.50	318	8.00	203	10.00	254	6.75	171	11.25	286	4.50	114	0.375	10
SSD-C-1000	10.00	254	13.00	330	9.00	229	11.00	279	7.50	191	12.50	318	5.00	127	0.375	10
SSD-C-1100	11.00	279	14.75	375	10.00	254	12.00	305	8.25	210	13.75	349	5.50	140	0.50	13
SSD-C-1200	12.00	305	15.25	387	11.00	279	13.00	330	9.00	229	15.00	381	6.00	152	0.50	13

Dimension shown in **inches** (bold) and millimeters. Refer to the SSD-C AutoCAD file for individual system drawings.

LOAD TABLE	
	Auto (Low Speed)
	Passenger Cart
	Scissor Lift
	Maintenance Cart
	Safe Walking Surface

Note: The SSD-C loading capabilities shown above are based upon average equipment weights, wheel types and sizes. For project-specific loading capabilities, contact MM Systems with technical data related to wheel type, contact area (footprint), distributed load per wheel, and speed of traffic.

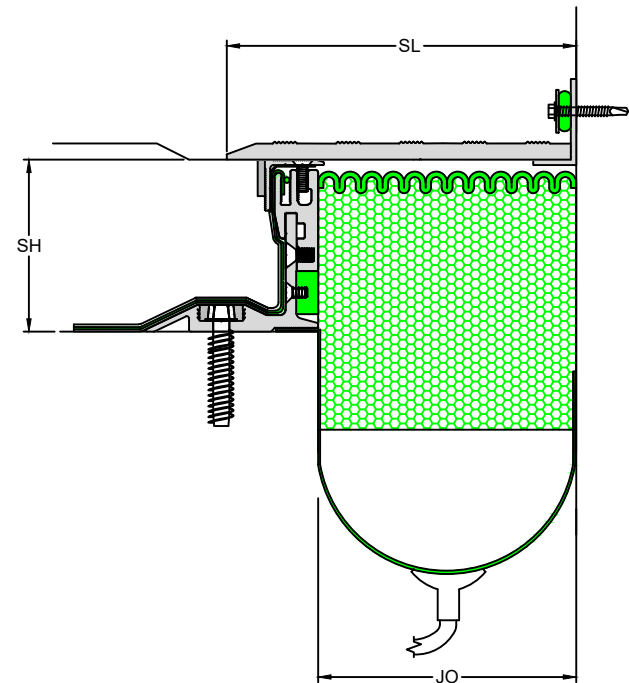

50 MM WAY
PENDERGRASS, GA. 30567
706-824-7500 PHONE

www.mm.systems

For Spec-Data, Install Guides, and other data visit www.mm.systems

RIGHTS OF DESIGN

All rights of design, detail, engineering and/or invention contained herein are the property of MM Systems and hereby reserved and are not to be reproduced or provided to any other party. MM Systems reserves the right to amend or withdraw any information contained herein without notice and will not be liable for any inaccuracy or ambiguity of said information.

Split-Slab Dual Seismic Foam Seal System

SSD-C Series (400-1200)

Drawn by:

LRM

Scale:

NTS

Drawing Number:

SHT. 2 OF 3

Issue Date:
07/10/2025

220324-02

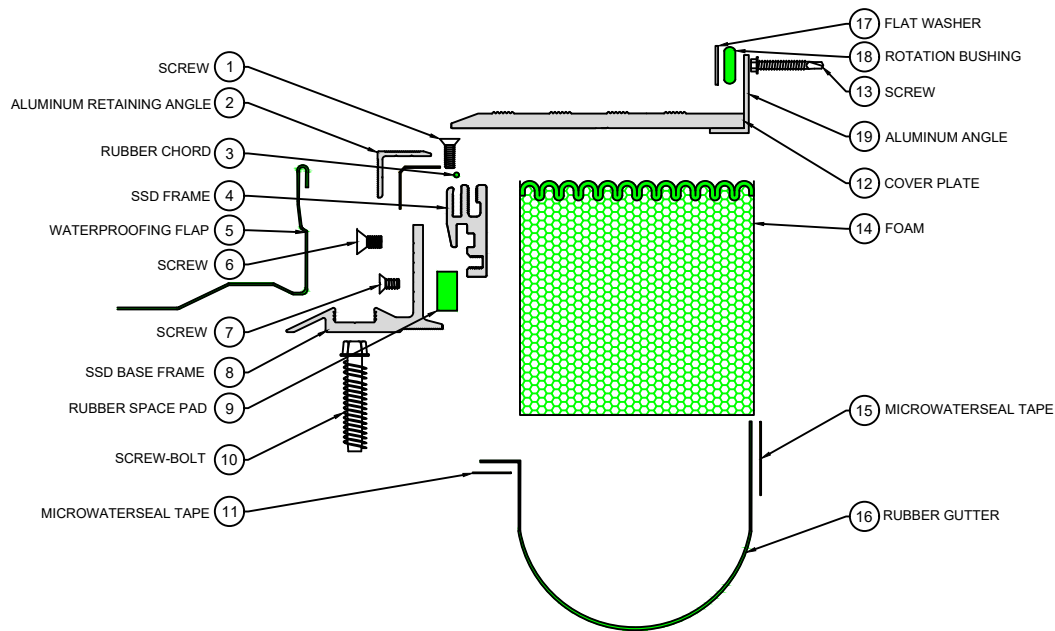

EXPLODED VIEW ▲

▼ PART NUMBERS

Locator	Part Component	SSD-C-400	SSD-C-500	SSD-C-600	SSD-C-700	SSD-C-800	SSD-C-900	SSD-C-1000	SSD-C-1100	SSD-C-1200
1	Screw	9382	9382	9382	9382	9382	9382	9382	9382	9382
2	Aluminum Retaining Angle	8408	8408	8408	8408	8408	8408	8408	8408	8408
3	Rubber Chord	9457	9457	9457	9457	9457	9457	9457	9457	9457
4	SSD Frame	8346	8346	8346	8346	8346	8346	8346	8346	8346
5	Waterproofing Flap	9118-12	9118-12	9118-12	9118-12	9118-12	9118-12	9118-12	9118-12	9118-12
6	Screw	9348	9348	9348	9348	9348	9348	9348	9348	9348
7	Screw	9558-1/2	9558-1/2	9558-1/2	9558-1/2	9558-1/2	9558-1/2	9558-1/2	9558-1/2	9558-1/2
8	SSD Base Frame	See Base Frame Chart	See Base Frame Chart	See Base Frame Chart	See Base Frame Chart	See Base Frame Chart	See Base Frame Chart	See Base Frame Chart	See Base Frame Chart	See Base Frame Chart
9	Rubber Space Pad	8312-1/4	8312-1/4	8312-1/4	8312-1/4	8312-1/4	8312-1/4	8312-1/4	8312-1/4	8312-1/4
10	Screw-Bolt	7420	7420	7420	7420	7420	7420	7420	7420	7420
11	Microwaterseal Tape	Microwaterseal60X 1	Microwaterseal60X 1	Microwaterseal60X 1	Microwaterseal60X 1	Microwaterseal60X 1	Microwaterseal60X 1	Microwaterseal60X 1	Microwaterseal60X 1	Microwaterseal60X 1
12	Cover Plate	7146#0504-M-10	7147#0800-M-10	7147#0800-M-10	7148#1012-M-10	7148#1012-M-10	7149#1300-M-10	7149#1300-M-10	7150#1508-M-10	7150#1508-M-10
13	Screw	9402	9402	9402	9402	9402	9402	9402	9402	9402
14	Foam	7528-400	7528-500	7528-600	7528-700	7528-800	7528-900	7528-1000	7528-1100	7528-1200
15	Microwaterseal Tape	Microwaterseal30X 2	Microwaterseal30X 2	Microwaterseal30X 2	Microwaterseal30X 2	Microwaterseal30X 2	Microwaterseal30X 2	Microwaterseal30X 2	Microwaterseal30X 2	Microwaterseal30X 2
16	Rubber Gutter	9109-12	9109-14	9109-14	9109-18	9109-18	9109-24	9109-24	9109-26	9109-26
17	Flat Washer	8312-1/4	8312-1/4	8312-1/4	8312-1/4	8312-1/4	8312-1/4	8312-1/4	8312-1/4	8312-1/4
18	Rotation Bushing	9455	9455	9455	9455	9455	9455	9455	9455	9455
19	Aluminum Angle	8404-M-10	8404-M-10	8404-M-10	8404-M-10	8404-M-10	8404-M-10	8404-M-10	8404-M-10	8404-M-10

Frame Height	Base Frame
3.25"	7431#0200
3.50"	7431#0204
3.75"	7431#0208
4.00"	7431#0212
4.25"	7431#0300
4.50"	7431#0304
4.75"	7431#0308
5.00"	7431#0312
5.25"	7431#0400
5.50"	7431#0404
5.75"	7431#0408
6.00"	7431



50 MM WAY
PENDERGRASS, GA. 30567
706-824-7500 PHONE

www.mm.systems

For Spec-Data, Install Guides, and other data visit www.mm.systems

RIGHTS OF DESIGN

All rights of design, detail, engineering and/or invention contained herein are the property of MM Systems and hereby reserved and are not to be reproduced or provided to any other party. MM Systems reserves the right to amend or withdraw any information contained herein without notice and will not be liable for any inaccuracy or ambiguity of said information.

Split-Slab Dual Seismic Foam Seal System

SSD-C Series (400-1200)

Drawn by:

LRM

Scale:

NTS

Drawing Number:

SHT. 3 OF 3

Issue Date:
07/10/2025

220324-02