

SCG-LP Series Expansion Joint

Sizes 200 through 1200

(Slab-to-Slab)



MM[®]
SYSTEMS

50 MM WAY
PENDERGRASS, GA. 30567
706-824-7500 PHONE

www.mm.systems

For Spec-Data, Install Guides, and other data visit www.mm.systems

RIGHTS OF DESIGN

All rights of design, detail, engineering and/or invention contained herein are the property of MM Systems and hereby reserved and are not to be reproduced or provided to any other party. MM Systems reserves the right to amend or withdraw any information contained herein without notice and will not be liable for any inaccuracy or ambiguity of said information.

Split Slab Membrane Cover Plate Gutter System

SCG-LP Series

Drawn by:

LRM

Scale:

NTS

Drawing Number:

SHT. 1 OF 3

Issue Date:

07/15/2025





NY211020-01

SCG-LP SERIES EXPANSION JOINT MOVEMENT CHART

Model Number	Joint Opening (JO ^M)		Slide Plate Width (SW ^M)		Thermal Movement (JO ^T)				Seismic Movement (JO ^S)				Total (JO ^A)	
	Nominal		Nominal		Minimum		Maximum		Minimum		Maximum		Movement	
SCG-200-LP	2.00	51	8.00	203	1.00	25	4.00	102	0.25	6	4.00	102	3.75	95
SCG-400-LP	4.00	102	10.00	254	1.00	25	6.00	152	0.25	6	6.00	152	5.75	146
SCG-600-LP	6.00	152	13.00	330	1.00	25	9.00	229	0.25	6	9.00	229	8.75	222
SCG-800-LP	8.00	203	16.00	406	1.00	25	12.00	305	0.25	6	12.00	305	11.75	298
SCG-1000-LP	10.00	254	19.00	483	1.00	25	15.00	381	0.25	6	15.00	381	14.75	375
SCG-1200-LP	12.00	304	22.00	559	1.00	25	18.00	457	0.25	6	18.00	457	17.75	451

Dimension shown in **inches** (bold) and millimeters. Refer to the SCG-LP AutoCAD file for individual system drawings.

LOAD TABLE

	Safe Walking Surface
	ADA Compliant
	Extreme Weather
	Shopping Cart

Note: The SCG-LP loading capabilities shown above are based upon average equipment weights, wheel types and sizes. For project-specific loading capabilities, contact MM Systems with technical data related to wheel type, contact area (footprint), distributed load per wheel, and speed of traffic.

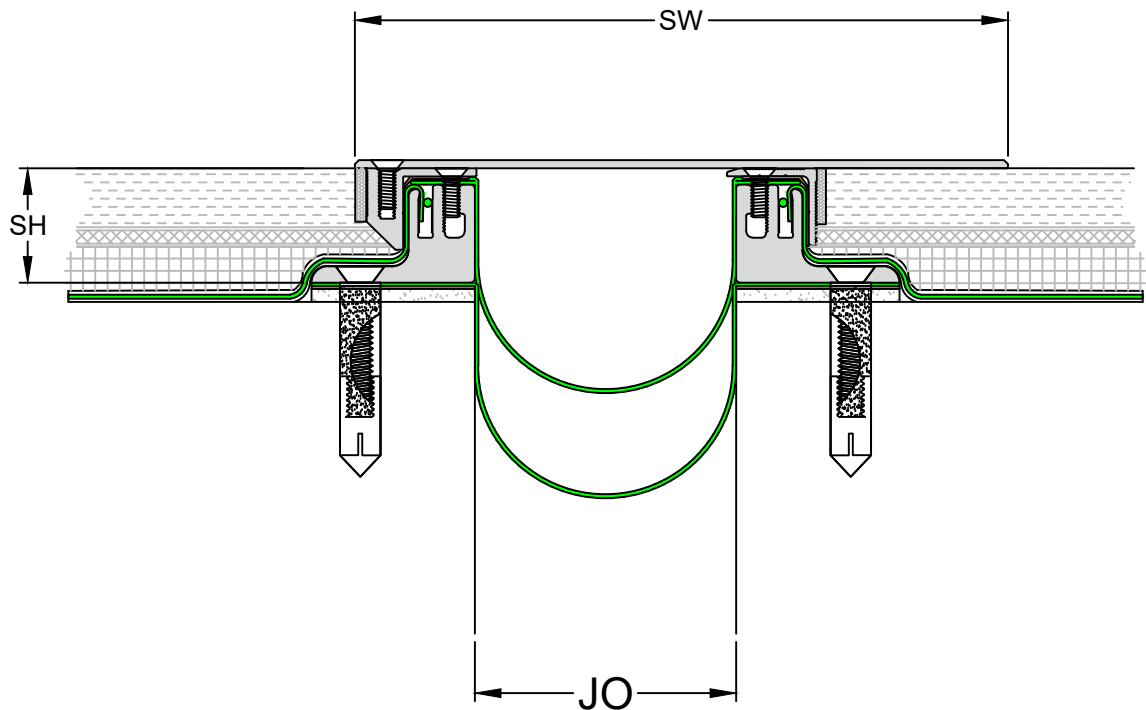

50 MM WAY
PENDERGRASS, GA. 30567
706-824-7500 PHONE

www.mm.systems

For Spec-Data, Install Guides, and other data visit www.mm.systems

RIGHTS OF DESIGN

All rights of design, detail, engineering and/or invention contained herein are the property of MM Systems and hereby reserved and are not to be reproduced or provided to any other party. MM Systems reserves the right to amend or withdraw any information contained herein without notice and will not be liable for any inaccuracy or ambiguity of said information.

Split Slab Membrane Cover Plate Gutter System

SCG-LP Series

Drawn by:

LRM

Scale:

NTS

Drawing Number:

SHT. 2 OF 3

Issue Date:

07/15/2025

NY211020-01

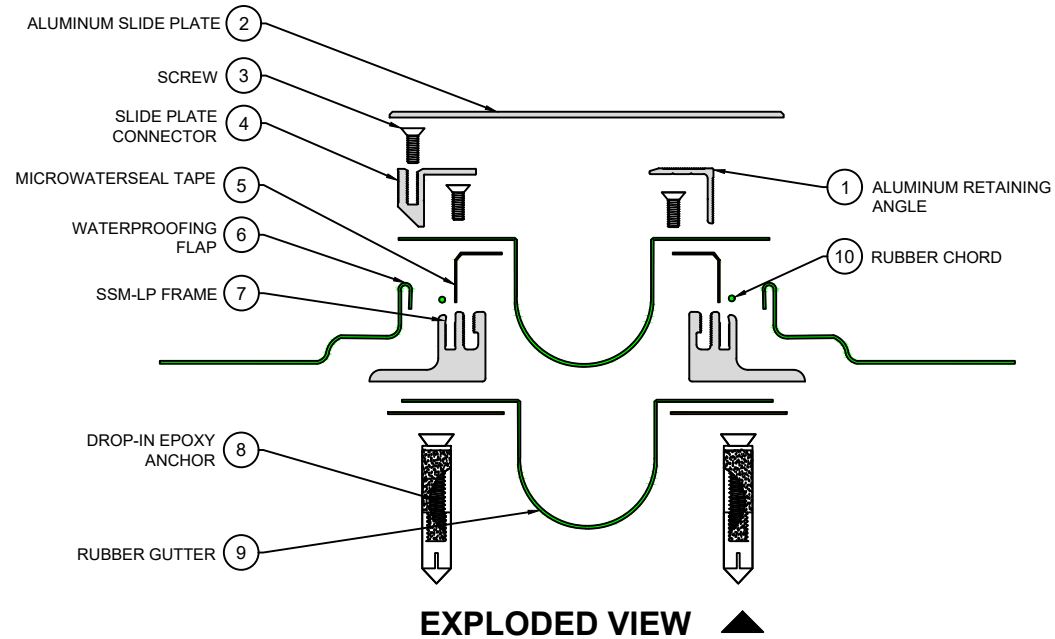

EXPLODED VIEW ▲

PART NUMBERS ▼

Locator	Part Component	SCG-LP-200	SCG-LP-400	SCG-LP-600	SCG-LP-800	SCG-LP-1000	SCG-LP-1200
1	Aluminum Retaining Angle	7025-M-10	7025-M-10	7025-M-10	7025-M-10	7025-M-10	7025-M-10
2	Aluminum Slide Plate	CPCA-AM-10-0800-00-1 2	CPCA-AM-10-1000-00-1 2	CPMB-AM-10-1300-00-1 2	CPMB-AM-10-1600-00-1 2	CPMB-AM-10-1900-00-1 2	CPMC-AM-10-2200-00-1 2
3	Screw	9382	9382	9382	9382	9382	9382
4	Slide Plate Connector	8415-M-10	8415-M-10	8415-M-10	8415-M-10	8415-M-10	8415-M-10
5	Microwaterseal Tape	Microwaterseal60X1	Microwaterseal60X1	Microwaterseal60X1	Microwaterseal60X1	Microwaterseal60X1	Microwaterseal60X1
6	Waterproofing Flap	9118-12	9118-12	9118-12	9118-18	9118-18	9118-18
7	SCG-LP Frame	8360-M-10	8360-M-10	8360-M-10	8360-M-10	8360-M-10	8360-M-10
8	Drop-In Epoxy Anchor	9527	9527	9527	9527	9527	9527
9	Rubber Gutter	9109-12	9109-12	9109-12	9109-18	9109-18	9109-18
10	Rubber Chord	9457	9457	9457	9457	9457	9457



50 MM WAY
PENDERGRASS, GA. 30567
706-824-7500 PHONE

www.mm.systems

For Spec-Data, Install Guides, and other data visit www.mm.systems

RIGHTS OF DESIGN

All rights of design, detail, engineering and/or invention contained herein are the property of MM Systems and hereby reserved and are not to be reproduced or provided to any other party. MM Systems reserves the right to amend or withdraw any information contained herein without notice and will not be liable for any inaccuracy or ambiguity of said information.

Split Slab Membrane Cover Plate Gutter System

SCG-LP Series

Drawn by: LRM	Scale: NTS	Drawing Number: NY211020-01
SHT. 3 OF 3	Issue Date: 07/15/2025	