

STC Series Expansion Joint
Sizes 1000 through 1800
(Floor-to-Floor)



50 MM WAY
 PENDERGRASS, GA. 30567
 706-824-7500 PHONE

www.mm.systems

For Spec-Data, Install Guides, and other data visit www.mm.systems

RIGHTS OF DESIGN

All rights of design, detail, engineering and/or invention contained herein are the property of MM Systems and hereby reserved and are not to be reproduced or provided to any other party. MM Systems reserves the right to amend or withdraw any information contained herein without notice and will not be liable for any inaccuracy or ambiguity of said information.

Seismic Flush Metal Cover Expansion Joint





STC Series (1000-1800)

Drawn by: LRM	Scale: NTS	Drawing Number: 17000-01
SHT. 1 OF 3	Issue Date: 01/03/2023	

STC SERIES EXPANSION JOINT MOVEMENT CHART / 50% MOVEMENT

Model Number	Joint Opening (JO ^N)		Thermal Movement (JO ^T)				Seismic Movement (JO ^S)				Total (JO ^A)		Slide Plate Width (SW)	
	Nominal		Minimum		Maximum		Minimum		Maximum		Movement			
STC-1000	10.00	254	9.50	241	10.50	267	5.00	127	15.00	381	10.00	254	16.00	406
STC-1200	12.00	305	11.50	292	12.50	318	6.00	152	18.00	457	12.00	305	19.00	483
STC-1400	14.00	356	13.50	343	14.50	368	7.00	178	21.00	533	14.00	356	22.00	559
STC-1600	16.00	406	15.50	394	16.50	419	8.00	203	24.00	610	16.00	406	25.00	635
STC-1800	18.00	457	17.50	445	18.50	470	9.00	229	27.00	686	18.00	457	28.00	711

Dimension shown in **inches** (bold) and millimeters. Refer to the STC AutoCAD file for individual system drawings.

LOAD TABLE	
	Safe Walking Surface
	Hand Truck
	Shopping Cart
	Utility Cart
	Floor Polisher

Note: The STC loading capabilities shown above are based upon average equipment weights, wheel types and sizes. For project-specific loading capabilities, contact MM Systems with technical data related to wheel type, contact area (footprint), distributed load per wheel, and speed of traffic.

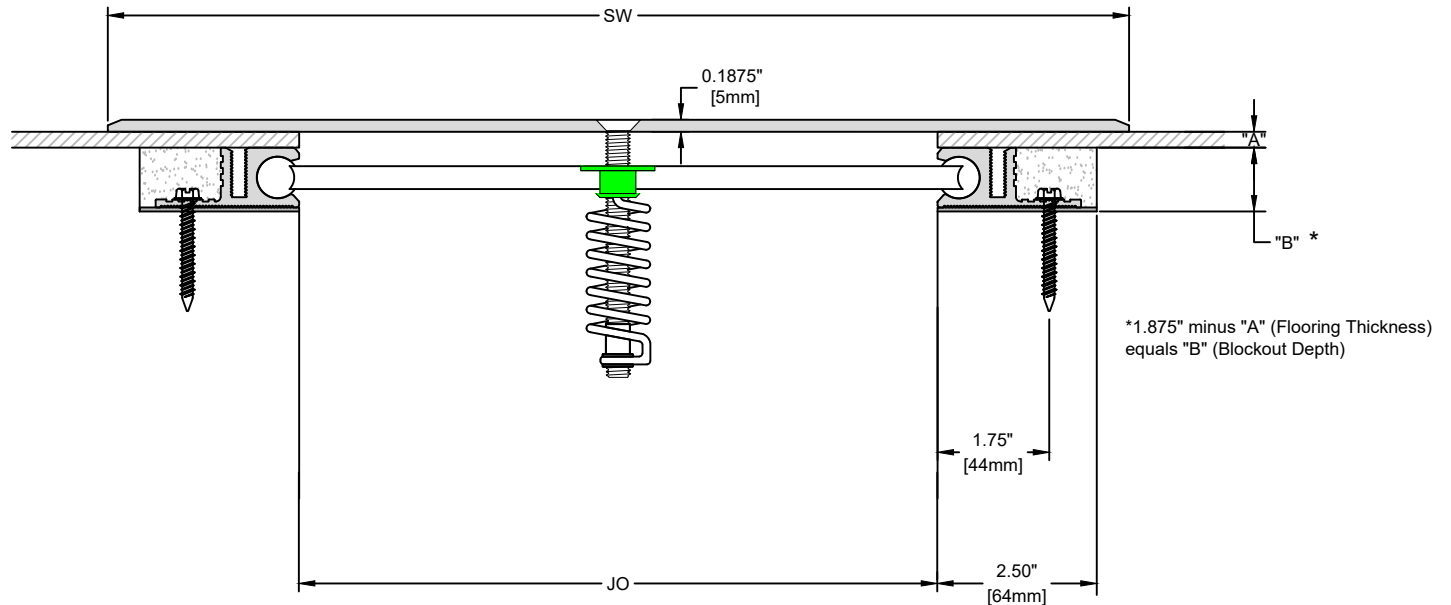

50 MM WAY
PENDERGRASS, GA. 30567
706-824-7500 PHONE

www.mm.systems

For Spec-Data, Install Guides, and other data visit www.mm.systems

RIGHTS OF DESIGN

All rights of design, detail, engineering and/or invention contained herein are the property of MM Systems and hereby reserved and are not to be reproduced or provided to any other party. MM Systems reserves the right to amend or withdraw any information contained herein without notice and will not be liable for any inaccuracy or ambiguity of said information.

Seismic Flush Metal Cover Expansion Joint

STC Series (1000-1800)

Drawn by:

LRM

Scale:

NTS

Drawing Number:

SHT. 2 OF 3

Issue Date:

01/03/2023

17000-01

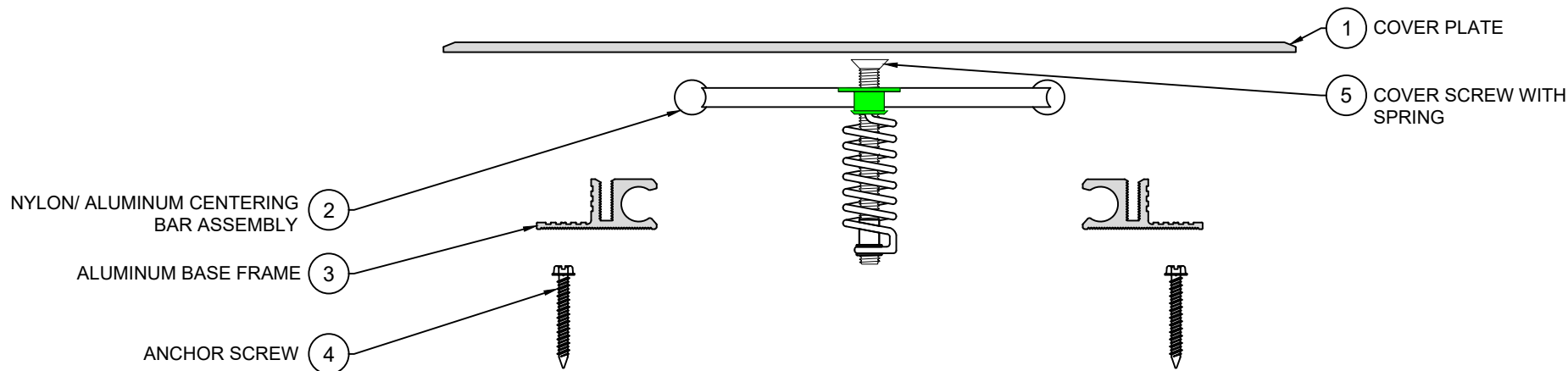

NOTE: LOKCRETE® BEDDING COMPOUND (8333) Not shown.

EXPLODED VIEW ▲

PART NUMBERS ▼

Locator	Part Component	STC-1000	STC-1200	STC-1400	STC-1600	STC-1800
1	Cover Plate	CPBB-AT-10-1600-02-2 4	CPBB-AT-10-1900-02-2 4	CPBB-AT-10-2200-02-2 4	CPBB-AT-10-2500-02-2 4	CPBB-AT-10-2800-02-2 4
2	Nylon/ Aluminum Centering Bar Assembly	ASSY-SCD-1700-N	ASSY-SCD-2000-S001-N	ASSY-SCD-2400-S001-N	ASSY-SCD-2600-S001-N	ASSY-SCD-3000-S001-N
3	Aluminum Base Frame	7128-M-10	7128-M-10	7128-M-10	7128-M-10	7128-M-10
4	Anchor Screw	9397	9397	9397	9397	9397
5	Cover Screw with Spring	8325	8325	8325	8325	8325



50 MM WAY
PENDERGRASS, GA. 30567
706-824-7500 PHONE

www.mm.systems

For Spec-Data, Install Guides, and other data visit www.mm.systems

RIGHTS OF DESIGN

All rights of design, detail, engineering and/or invention contained herein are the property of MM Systems and hereby reserved and are not to be reproduced or provided to any other party. MM Systems reserves the right to amend or withdraw any information contained herein without notice and will not be liable for any inaccuracy or ambiguity of said information.

Seismic Flush Metal Cover Expansion Joint

STC Series (1000-1800)

Drawn by: LRM	Scale: NTS	Drawing Number: 17000-01
SHT. 3 OF 3	Issue Date: 01/03/2023	